

STORAGETECH®

An ERGIL Group Brand



ATEX approved



Non-Atmospheric Gauge Hatch

model number 220

Product Description

STORAGETECH® Non-Atmospheric Gauge Hatch Model Number 220 is a specially designed ultra performance gauge hatch that is unlike others on the market; it prevents liquid to be incontact with the atmosphere. It minimizes the vapor losses and odor. This safety device has a special locking system that prevents unauthorized access to the storage tank. They are typically mounted to a flange, which connects the vapor space of a storage tank.

Product Benefits

- StorageTech Sampling Gauge Hatch Closed to Atmosphere Model Number 220 prevents evaporation losses.
- Protect s environment. Model Number 220 prevents green house gasses from mixing the atmosphere, and minimizes the product odors around the surrounding area.
- PVV provide safety for your storage facility. Model Number 220 protects your storage tank.
- Provides tank access where manual level gauging, temperature measurement or sampling is required.
- Lockable cover prevents unauthorized access to the storage tank.

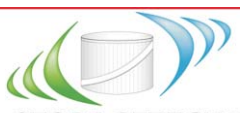

STORAGETECH®

An ERGIL Group Brand

Key Features

- StorageTech Model Number 220 provides Teflon seal for a longer service period, and reduces the spare cost.
- The Locking-system is durable against petrochemical vapors.
- Non-sparking design
- Foot pedal helps you to open the cover without using your hands, and lockable cover - Easy to install. You do not need a special tool or experience to install the StorageTech Model 220.
- StorageTech Model 220 comes with the paint color you choose.

Manufacturing Materials

Body Material	Gasket	Arm	Disk	Cover
Carbon Steel	P.T.F.E	Carbon Steel	Carbon Steel	Carbon Steel
304 S.S.		304 S.S.	304 S.S.	304 S.S.
316 S.S		316 S.S	316 S.S	316 S.S
Aluminum		Aluminum	Aluminum	Aluminum

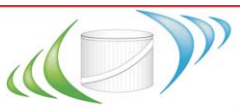

STORAGETECH®

An ERGIL Group Brand

Dimension and Weights

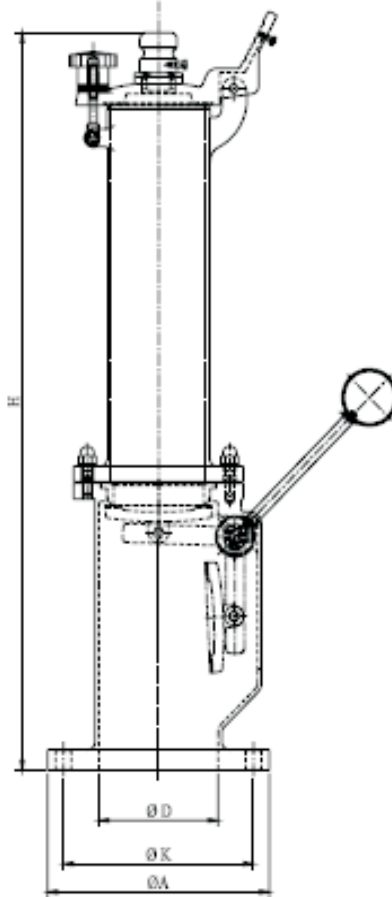

Model	D Nominal Conn. Diameter Inch (mm)	A Outside Diameter Inch (mm)	H Height Inch (mm)	K Diameter Inch (mm)	Aluminum Unit Weight Lb (kg)
220	6" (150)	11" (280)	35-3/7" (899.5)	9-4/9" (240)	42 (19)

Dimension and Weights